

NOFIRNO RISE ULTRA CRUSHER

Flexible Plastic Pipe Penetration Sealing System

For A0 - A60, watertight & gastight ratings

The NOFIRNO RISE ULTRA Plastic Pipe Sealing System is one of the most adaptive systems for sealing straight and angled pipe penetrations and can even accommodate multiple pipe runs. The system is designed to maintain the safety of vessels providing fire protection and ensuring bulkheads and decks remain gas and watertight when pipes need to pass through them. It consists of only three components: NOFIRNO sealant; a silicone based fire resistant, water repellent sealant, RISE ULTRA EXPANDING CRUSHER sleeves and NOFIRNO multi-filler sleeves, supplied in bonded strips to make the system easy to install.

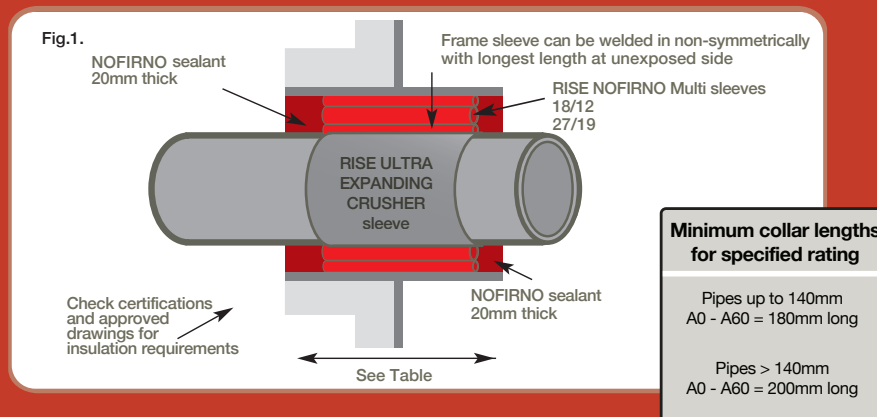

TOOLS REQUIRED:

- High ratio sealant gun (25:1)
- Long nosed pliers
- Approved degreasing wipes (De-solv-it 4000GDW)
- Cellulose sponges
- Cartridge cutter
- Torch
- Disposable nitrile gloves (Ansell Touch N Tuff)
- Water spray
- Sleeve cutting tool
- Metal rule (150mm)
- Dead blow hammer
- Wooden depth gauge (marked at 20mm)
- Longer cartridge nozzles & angle connectors

INSTALLATION INSTRUCTIONS PLASTIC PIPE APPLICATIONS



1. Make a visual inspection of the penetration, ensure all obstructions are removed and the penetration frame is painted or has a primer coating applied. Check length of the penetration frame against certification requirement. See fig.1.

2. A correctly fitting RISE ULTRA EXPANDING CRUSHER sleeve is applied around each plastic pipe. See Table 1.

3. Use approved degreaser wipes to thoroughly clean all surfaces where sealant will be applied. All dirt, dust or oil must be removed from inside 20-30mm edge of the penetration and the outside of any service pipe. Several wipes may be needed. The NOFIRNO sealant will not bond to any surface that is not clean and dry.

4. Use NOFIRNO filler sleeves to tightly pack the free space between the RISE ULTRA EXPANDING CRUSHER sleeve and penetration frame. The larger 27/19 multi sleeve should be used to pack this space with smaller 18/12 multi sleeves used to fill smaller gaps. Multi sleeves can easily be separated in to smaller quantities.

5. Push NOFIRNO filler sleeves and RISE ULTRA EXPANDING CRUSHER sleeve in to the penetration frame leaving 20mm free space at the front. Use a wooden depth gauge marked at 20mm & long nosed pliers to adjust the sleeves to the correct depth. Allowing correct 20mm depth will ensure a suitable layer of sealant is applied. Ensure these are still tightly packed ready for application of the sealant layer. Install additional sleeves if required.

6. A sealant layer should be installed at both ends of the penetration. Before application of the sealant layer, use the degreaser wipes to clean the surfaces again to ensure that all dirt and oil residue is removed.

7. Using a specialist high ratio caulking gun (min ratio 25:1) apply NOFIRNO sealant across face of penetration. Apply the sealant against the inside edge of the penetration & around outside edge of each service pipe to the full 20mm deep layer required. This will help ensure a good bond is made with each surface. Apply sealant across the rest of the penetration face and against the sleeves allowing it to fill out to the required 20mm depth, ensure there are no gaps. A slight overfill is required. When working with NOFIRNO sealant we recommend using disposable nitrile gloves. Sealant cannot be applied on surfaces over 60 Deg C. (After curing service operating temperature max 180 Deg C)

8. Using a water spray dampen a cellulose sponge (this prevents sealant sticking to the sponge, soapy water MUST NOT be used). Use a dabbing motion to firmly pat down the NOFIRNO sealant ensuring the sealant makes good contact with the penetration frame and the service pipe.

9. The sealant layer should now be finished off by hand. Use the water spray to wet your nitrile gloves, this will ensure sealant does not stick to the glove. A good smooth finish can be obtained by using a fast skimming motion.

10. Use a torch to take final inspection of the sealant layer. Ensure the penetration is fully sealed and the finish is good. Any areas that do not seem sufficiently sealed add more sealant in this area and smooth off as before. Clean excess sealant from edge of penetration & service pipe. Complete second sealant layer using the same method. Curing the sealant layer is dependent on air humidity and environmental temperature. Generally curing will occur at 1 to 2mm per day.

Table 1

Plastic Pipe Diameter	RISE ULTRA CRUSHER (length 210mm)*	Alternative RISE Wrap (1000x2.5x210mm)	Max air gap allowable	Plastic Pipe Diameter	RISE ULTRA CRUSHER (length 210mm)*	Alternative RISE Wrap (1000x2.5x210mm)	Max air gap allowable
16mm	35/16	1x Wraps around BAE no. C75CDX1038	3mm	60mm	100/63	3x Wraps around BAE no. C75CDX1038	6mm
18mm	35/18	1x Wraps around	3mm	75mm	100/75	4x Wraps around	6mm
20mm	40/20	1x Wraps around	3mm	90mm	125/90	4x Wraps around	6mm
25mm	50/25	1x Wraps around	3mm	110mm	154/110	6x Wraps around	10mm
32mm	50/32	2x Wraps around	3mm	125mm	160/125	8x Wraps around	10mm
40mm	50/40	2x Wraps around	3mm	140mm	202/140	8x Wraps around	10mm
50mm	77/50	2x Wraps around	3mm	160mm	202/160	8x Wraps around	10mm

The number of wraps required shown above is the minimum required to meet the certification requirements.

When using the wrap, if the Max air gap is larger than that shown in the last column, NOFIRNO filler sleeves should also be installed to reduce the annular gap or alternatively can be completely filled using the wrap.

5 POINT FINAL CHECK

- Is there a correctly fitting RISE ULTRA EXPANDING CRUSHER sleeve around each plastic pipe?
- Is there sufficient sealant applied?
- Are there any gaps in sealant layer?
- Is the sealant in good contact with penetration frame?
- Is the sealant in good contact with the service pipe?

Please see separate instructions for metallic, GRP and electrical cable applications.

*Please note that other sizes are available. Contact CSD for further details.

CSD Sealing Systems
Unit 6, Easter Park,
Nelson Park West,
Cramlington NE23 1WQ

Tel: 01670 739970
Fax: 01670 716548
Information: info@csdsealingsystems.co.uk
www.csdsealingsystems.co.uk

**SAFETY.
RELIABILITY.
INGENUITY.**